

DEPTH & LEVEL TRANSMITTER PSLM – Ø16 mm

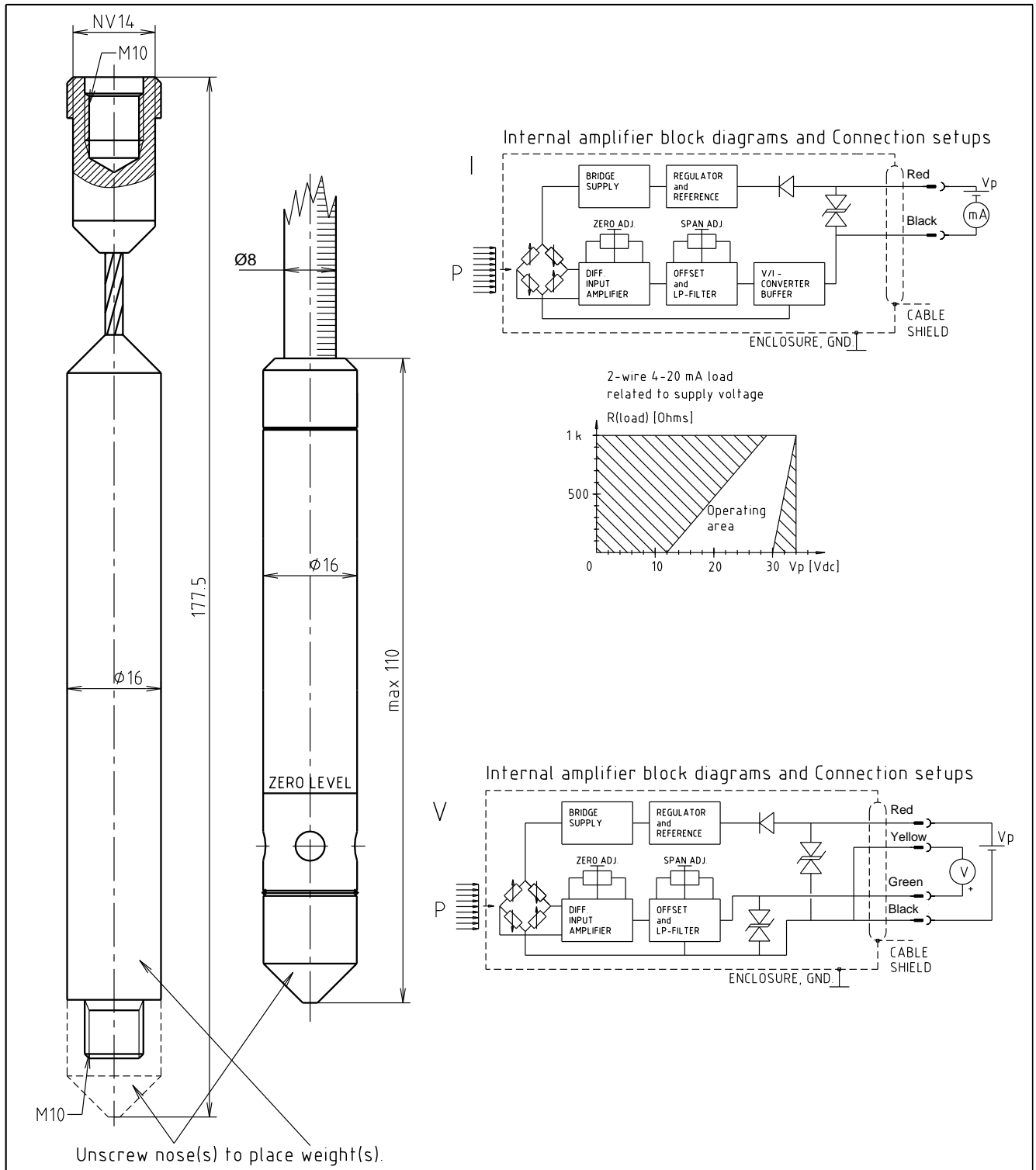

DESCRIPTION

The pressure transmitter is based on a piezoresistive silicon sensor. The stainless steel part is laser welded to the stainless steel tube that contains the amplifier. The backside of the sensor (gauge version) is ventilated to the atmosphere through a polyamide tube in the cable. The shield in the cable is connected to the stainless steel housing. All transmitters are leak tested with helium. The transmitter is terminated with a removable protective cone made of PVC (threaded with M10). The thread can be used for adding additional weight.

SPECIFICATIONS

Pressure ranges	1, 2, 4, 5, or 10 bar gauge. 10, 20, 40, 50, or 100 mWC gauge. Intermediate ranges possible.
Pressure limit	2 times rated pressure without damage.
Material	Stainless steel AISI 316.
Supply voltage	I: 12-30 V _{DC} , 4 mA + output signal current. V: 9-30 V _{DC} , max 4 mA. S: 5 V _{DC} , max 4 mA.
Supply voltage effect	< 0.03 %/V.
Output signal	I: 4-20 mA (R _L see diagram) 2 wires. V: 1-5 V R _L > 10 kohm 4 wires. S: 0.1-3.4 V R _L > 100 kohm 4 wires. The wire colors for S is as for V on the block diagram
Frequency range	DC-300 Hz (-3 dB).
Temperature range (compensated)	-2 °C to +30 °C.
Temperature effects (total error band of FSO)	< ± 0.5 %.
Non-linearity	< 0.25 %.
Repeatability	< 0.05 %
Transducer weight	100 grams.
Surge immunity	According to IEC 61000-4-5: 1995 + Corr1: 1995 2 kV/42 Ohm between wires 4 kV/2 Ohm on cable shield
Cable	Outer insulation: Ø8 mm black PUR. Wires: 4x0.25 mm ² PVC insulated wires. Ventilation: ø2.5 mm polyamid capillary tube. Weight: 50 g/m.
Protection class	2 times range, minimum 20 mWC

ORDERING INFORMATION

PSLM x x / x

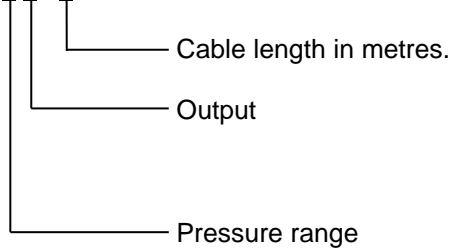

I: 4-20 mA
V: 1-5 V
S: 0.1-3.4 V

b: bar
m: meter water column

PSL-16 300 g extra weight (stainless steel AISI 316)