

DISPLACEMENT TRANSDUCER

LDW 16/ - differential inductance

LDW 16/ S – springloaded core movement

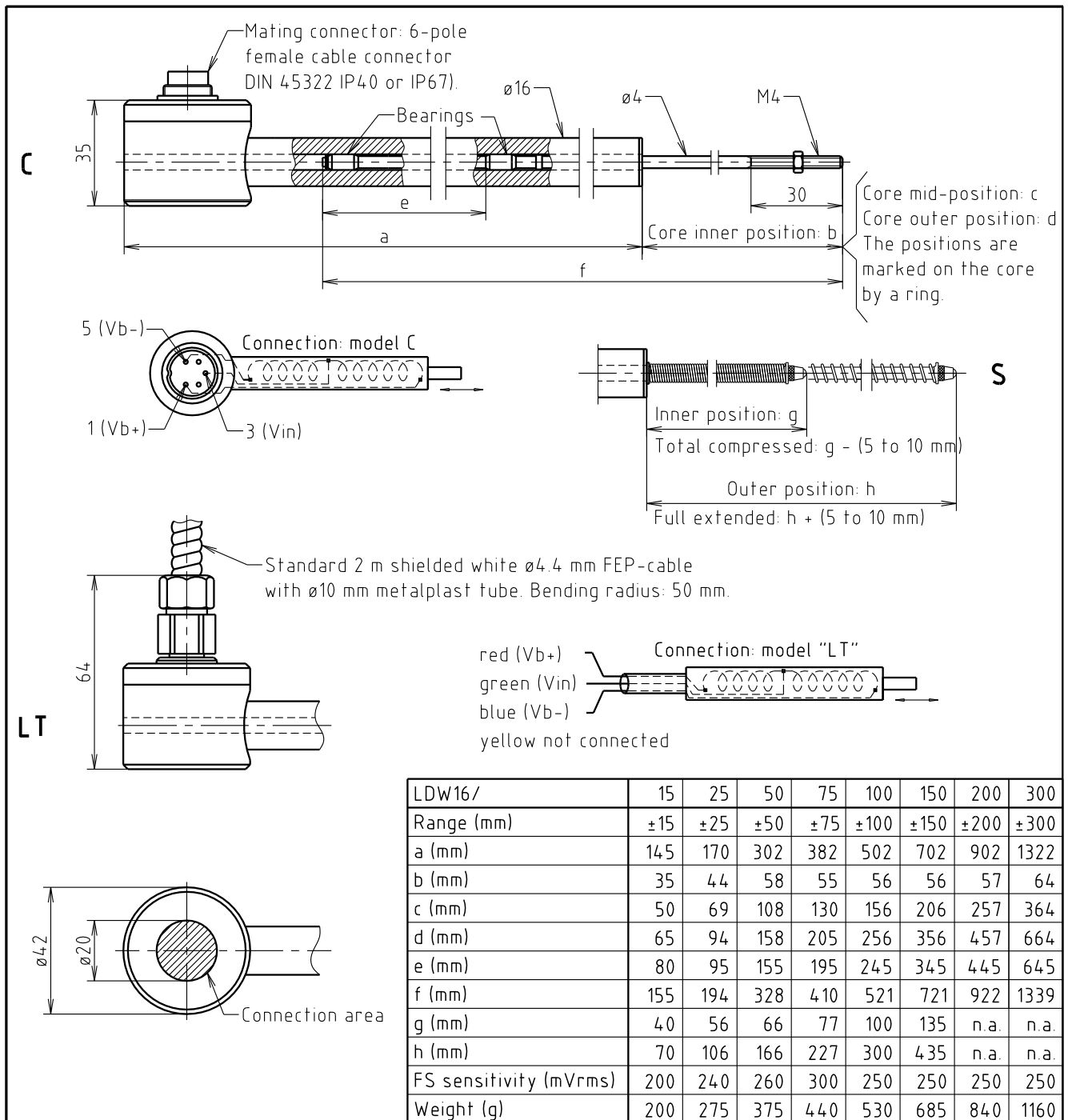

DESCRIPTION

The LDW 16/ inductive displacement transducer is based on differential coils in a half-bridge configuration. With the core in center position the two coil impedances are the same. If the core is moved the coil impedances go in opposite direction. When a carrier wave voltage is applied across the coils there is a linear relation between the generated mid-point voltage output and the core position. The basic principle makes the measurement electronically contactless and the two core teflon bearings in the bore liner offers excellent wear resistance – more than 100 mio. movements. All outer surfaces are made of high corrosion resistance stainless steel. This together with the watertight laserwelded construction ensures compatibility to most environments. The LDW 16/ can work with most carrier wave measuring amplifiers such as the HFJ ICA series.

2022-04-01

SPECIFICATIONS

Standard ranges	Please see table.
Carrier wave voltage	0.5 V _{RMS} to 15 V _{RMS} , nominal 5 V _{RMS}
Carrier wave frequency	2.5 kHz to 10 kHz, nominal 5 kHz.
Sensitivity	Please see table – Full Scale values with R _L = 110 kΩ
Non-linearity	< 0.5 % of FSO.
Temperature range - C and LT	-40 °C to +85 °C
Temperature coefficient of ZERO	< 0.01 %/°C of FSO.
Temperature coefficient of SPAN	< 0.05 %/°C of signal output
Transducer materials - coil housing - core	Austenitic stainless steel AISI 316. Ferritic stainless steel Sandvik 18.0.2.
Mechanical environment - vibration - shock	According to IEC 68-2-6 (10-150 Hz, 0.35 mm/5 g). According to IEC 68-2-27 (1000 g half sine, 1 ms).
Protection class	IP67.
Cable length	Standard 2 m. Max 100 m cable from sensor to electronics.
Spring force (only 'S'- models) - outer position - inner position	App. 0.3 kp. App. 0.4 kp.
Ball head dimensions (only 'S'- models) - ball diameter - thread	Ø3 mm. Outside M2.5. Different type of heads available.

INSTALLATION

To minimize wear, make sure that there is no bending of the transducer core when mounting. The coil housing is easily placed with one or two mounting blocks, MBO 16. NOTE! The anodized MBO 16 does not ground the transducer housing to the base on which it is mounted. The core rod ends with a M4 thread for easy attachment and it is marked at 3 positions indicating the nominal inner, mid and outer positions to ease mechanical installation and calibration. Before installation remove the yellow cap holding the core. A laserwelded stopring inside the bore liner prevents the core to fall out during installation. The cable respectively the connector shield is connected to the transducer housing. The opposite end of the connecting cable shield must be attached only to reference earth level of the associated electronics for best performance. Working with the "C"-version or extension cables, it is important that the mating connector house is connected to the cable shield.

ORDERING INFORMATION

LDW 16/x x/x x

Nothing	: Standard.
S	: Spring loaded core movement.
Nothing	: Standard 2 m cable.
"X"	: x metres cable length.
C	: House and connector.
LT	: House and protected radial cable.
"X"	: Range in ±mm.

MBO 16

: Mounting block – please see datasheet 3.3.2.1.